

REVIEW ARTICLE

Concise Reviews and Hypotheses in Food Science

Unlocking the secrets of Neapolitan pizza: A concise review of wood-fired, electric, and gas pizza ovens

 Aniello Falciano¹  | Paolo Masi¹  | Mauro Moresi² 
¹Department of Agriculture, University of Naples Federico II, Portici, Italy

²Department for Innovation in the Biological, AgroFood and Forestry Systems, University of Tuscia, VIA S C DE LELLIS, VITERBO, Lazio, Italy
Correspondence
 Mauro Moresi, Department for Innovation in the Biological, Agrofood and Forestry Systems, University of Tuscia, Viterbo, Italy.
 Email: mmoresi@unitus.it
Funding information

Italian Ministry of Instruction, University and Research, Grant/Award Numbers: PRIN 2017, 2017SFTX3Y_001

Abstract

This review explores the Neapolitan pizza baking process in a traditional wood-fired oven, employing visual color analysis and IR thermal scanning to detail heat exchange mechanisms. During cooking, the oven floor temperature in the pizza area decreased proportionally to the pizza's mass, whereas the free area maintained a constant temperature of $439 \pm 3^\circ\text{C}$. An IR thermal camera indicated that the oven dome temperature reached approximately 480°C with a weak flame and 500°C with a strong flame. The pizza's bottom achieved a maximum temperature of $100 \pm 9^\circ\text{C}$, facilitated by the Pizzaiolo's skill in lifting and rotating the pizza for uniform cooking. Top temperatures varied: up to 180°C for white pizza and 84°C and 67°C for tomato and Margherita pizzas, respectively. IRIS electronic eye analysis revealed more browning and blackening on the pizza's top compared to its bottom, with peaks of about 26% and 8% for white pizza, respectively. Rapid baking is pivotal in Neapolitan pizza-making, necessitating precise heat and mass transfer management to influence sensory attributes. European Commission Regulation No. 97/2010 mandates wood-fired ovens for true Neapolitan pizza, but environmental concerns prompted the Associazione Verace Pizza Napoletana to certify gas or electric ovens when wood-fired ovens are impractical. Operating costs vary: liquefied petroleum gas ovens are the costliest, with costs ranging from €5.38 to €6.19/h, whereas natural gas and electric ovens have operating costs between €2.70 and €4.10/h. At €0.15/kg, firewood is the most economical, supporting traditionalist views. However, natural gas and electric ovens present competitive costs under stringent antipollution laws, making them viable alternatives.

KEYWORDS

considerations for pizza oven selection, electric, gas and wood-fired oven characteristics, operating costs, pizza cooking process, true Neapolitan pizza

This is an open access article under the terms of the [Creative Commons Attribution](https://creativecommons.org/licenses/by/4.0/) License, which permits use, distribution and reproduction in any medium, provided the original work is properly cited.

© 2024 The Author(s). *Journal of Food Science* published by Wiley Periodicals LLC on behalf of Institute of Food Technologists.

1 | INTRODUCTION

Pizza is more than just a dish in Italy; it symbolizes the country's culture and culinary tradition and is a source of national pride that has spread worldwide, adapting to various tastes and styles. Despite numerous international variations, Italy remains the cradle of authentic pizza, known for its diversity and quality. Italian pizza-making traditions include a rich variety of doughs, sizes, shapes, and cooking techniques, each rooted in different regions. In Italy, approximately 5 million pizzas are consumed every day, including round pizzas, pizza by the slice, pan pizzas, and meter-long pizzas. This results in an average per capita consumption of 7.6 kg per year, which is significantly less than the average US per capita consumption of 13 kg per year (<https://www.cookist.it/chi-consuma-piu-pizza-al-mondo-la-risposta-ti-sorprendera/>; accessed on August 25, 2024).

A few pizza chains like Pizza Hut, Domino's, and Papa John's have helped to establish a strong cultural presence in North America, leading in innovation and adapting menus to changing consumer preferences with new flavors, crust options, and toppings.

Emerging markets in Asia-Pacific and Latin America are also experiencing significant growth in pizza consumption due to rapid westernization, the introduction of healthier variants (low-calorie, vegan, gluten-free), and the rising popularity of online pizza ordering through web portals and mobile apps. Technological advancements like customer preference tracking, robotic automation, integrated delivery systems, and ghost kitchens, along with marketing strategies, are also propelling growth (Research & Markets, 2024).

Owing to the COVID-19 pandemic, the segment of frozen pizzas and ready-to-use doughs has started experiencing significant growth. Frozen pizza manufacturers have invested significantly in research and development to offer products that come as close as possible to the quality of pizzeria-made pizza. This includes the use of high-quality ingredients, the adoption of slow-leavening techniques for the dough, and the use of wood-fired or stone ovens for cooking before freezing to maintain the authentic taste and desired texture (Research & Markets, 2024).

In 2023, the global pizza market reached a value of \$148.6 billion. It is expected to grow at a compound annual growth rate (CAGR) of 4.45% from 2023 to 2032, potentially reaching \$219.9 billion by the end of the period. The frozen pizza segment, valued at \$17.6 billion in 2023, is expected to grow at a CAGR of 5.3%, reaching \$28 billion by 2032 (Research & Markets, 2024).

Worldwide interest in pizza has focused particularly on the Neapolitan pizza, a very popular food in the Campania region of South Italy. European Commission

Regulation no. 97/2010 (EC, 2010) entered the name *Pizza Napoletana* in the register of traditional specialties guaranteed (TSG) to define and preserve its original characteristics, as requested by the Italian *Associazione Verace Pizza Napoletana* (AVPN—<https://www.pizzanapoletana.org/en/>; accessed on August 25, 2024). In 2017, UNESCO inscribed the art of the Neapolitan pizza maker (Pizzaiolo) on the Representative List of the Intangible Cultural Heritage of Humanity (UNESCO, 2017).

The Pizza Napoletana TSG consists of a circular 0.4-cm-thick base with a diameter no greater than 35 cm and a rim 1–2 cm thick, garnished in the central area. Only two garnishing sets are recognized: Marinara (with tomato, salt, extra-virgin olive oil, oregano, and garlic) and Margherita (with tomato, salt, mozzarella and grated cheeses, extra-virgin olive oil, and basil). This excludes numerous toppings used worldwide, maintaining the traditional sensory properties (AVPN, 2024).

All production steps (dough preparation, rising, shaping, garnishing, baking, and conservation), as well as main mistakes and defects, were fully described by Masi et al. (2015). The Pizza Napoletana TSG must be cooked exclusively in a wood-fired oven, using certified logs of oak, beech, ash, and maple that do not produce smoke or odors (EC, 2010). Due to criticism of high particulate emissions from wood-fired ovens, the AVPN now allows gas or electric ovens to obtain the true Neapolitan pizza collective mark, provided they are certified and approved. This ensures that the pizza is cooked in 60–90 s with the oven floor at 380°C–430°C and the dome at approximately 485°C.

Despite the worldwide fame of pizza, a search on the Scopus database revealed just 24 papers dealing with this food product. According to their titles, these papers addressed the following topics:

1. Cultural and sociological aspects of Neapolitan pizza (De Falco, 2018; Deacon, 2018; Ferulano, 2021; Morris & Ibba, 2018; Stazio, 2021).
2. Technology (Adighieri et al., 2010) and thermal aspects of electric (Ciarmiello & Morrone, 2016a, 2016b; Ciarmiello et al., 2017; Morrone & Ciarmiello, 2018) and wood-fired (Falciano et al., 2022a, 2023a, 2023b) pizza ovens.
3. Chemical, sensory, and nutritional properties of pizza (Caporaso et al., 2015; Della Corte et al., 2020; A. Falciano, et al., 2022b; Idelson et al., 2020; Pagani et al., 2014; Piscopo et al., 2023, 2024).
4. Physical and shelf-life studies of pizza dough (Covino et al., 2023; Falciano et al., 2023c).
5. Environmental impact and carbon footprint (Falciano et al., 2022c, 2023d).

To further extend the technical literature on pizza, this review aimed to better describe the cooking process of Neapolitan pizza in a traditional wood-fired oven and to detail the heat exchange mechanisms involved. This analysis serves as a foundation for examining the types of ovens currently in use, from wood-fired ovens to new gas and electric ovens, and for estimating their typical operating costs to enable a more accurate and scientifically based selection for pizza makers.

2 | NEAPOLITAN PIZZA BAKING PROCESS IN A TRADITIONAL WOOD-FIRED OVEN

The phenomenology of the baking process in a typical wood-fired pizza oven, like the one illustrated in Figure 1, was recently examined by Falciano et al. (2023a, 2023b). The research covered both the start-up phase of a newly built oven and its management under nearly stable (pseudo-stationary) operating conditions.

When commissioning a new wood-fired oven, it is essential to control the heat intensity during the initial firings to prevent the refractory bricks from cracking. Following the manufacturer's guidelines, 1 kg of firewood was added every 20 min for just 1 h on the first day, for 2 h on the second day, for 4 h on the third day, and for about 8 h on the fourth day, after which the oven was ready for regular use.

As shown in Figure 2, the heating process of the oven fueled with 3 kg/h of oak logs is highly repeatable. In fact, after 4–6 h from ignition, the average temperature of the dome (T_V) or the oven floor (T_{FL}) with an empty oven reaches $546 \pm 53^\circ\text{C}$ or $453 \pm 32^\circ\text{C}$, respectively.

The temperature of the dome of the wood-fired oven decreases during the pizza baking process. Using the same thermal imaging camera (FLIR E95 42°, FLIR System OU) as previously employed (Falciano et al., 2022, the time course of the dome temperature (T_V) was monitored during the baking of a Margherita pizza, as shown in Figure 3. When the flame is strong, the final temperature is around 499°C , with a standard deviation of $\pm 2^\circ\text{C}$ from an initial value of approximately 520°C . When the flame is weak, the final temperature drops to around $479 \pm 3^\circ\text{C}$, compared to an initial value of about 490°C .

In the pizza baking process, there is a simultaneous transfer of heat and mass that causes physical, chemical, and biochemical changes, such as browning of surfaces, evaporation of moisture leading to expansion of the base and rim, protein coagulation, and starch gelatinization. The browning phenomenon is caused by nonenzymatic chemical reactions like the Maillard reaction and caramelization. Both occur at high temperatures. The Maillard reaction involves reducing sugars and amino

acids, proteins, and/or other nitrogenous organic compounds, whereas caramelization involves sucrose and reducing sugars. Falciano et al. (2023) used CIE-Lab color indices to detect color changes in the upper and lower surfaces of the pizza.

Due to the nonuniform heat transfer during pizza baking, the upper face of the pizza, covered with toppings having different thermal properties (such as tomato, olive oil, mozzarella), heats up more slowly than the untopped outer rim (Falciano et al., 2023b), the latter swells rapidly due to water evaporation, as illustrated in Figure 4. Regardless of the toppings used, the thickness of the crust in the pizza increases on average from 0.8 ± 0.1 cm to 2.3 ± 0.3 cm in 80 s (Falciano et al., 2023b).

During the pizza baking process, the oven floor temperature (T_{FL}) remains consistently at $439 \pm 3^\circ\text{C}$, whereas the temperature of the area directly in contact with the pizza decreases more rapidly as the mass of the pizza increases, as illustrated in Figure 5.

During baking, gluten proteins aggregate and cross-link, imparting rigidity to the pizza's cellular structure. The rim and the bottom surface of the pizza reach temperatures suitable for achieving the desired crispiness. Typically, after 80 s of baking, the rim in all studied pizza types reached an average temperature (T_{SR}) of $150 \pm 13^\circ\text{C}$, except for the Margherita pizza, which, due to its heavier weight from the addition of mozzarella, reached this temperature after 100 s (Falciano et al., 2023b).

Therefore, the thickness and final temperature of the crust were essentially independent of the toppings used to garnish the pizza.

The bottom surface of the pizza does not adhere uniformly to the oven floor due to the formation of a laminar layer of stagnant air and/or evaporated water. As a result, at the end of baking, the average temperature (T_{SL}) reached an average value of $100 \pm 9^\circ\text{C}$ (Falciano et al., 2023b). Once again, the Margherita pizza, due to its greater weight (430 g), reached this temperature with a delay of 20 s compared to the other types of pizza considered (Falciano et al., 2023b).

At the end of baking, the temperature reached by the central upper surface of the pizza depends on the ingredients used for topping. For example, the white pizza (without any toppings) reaches approximately 180°C – 190°C , likely due to the greater absorption of radiant heat from the oven dome by the large dark brown areas that form on its surface (Falciano et al., 2023b). Spreading sunflower oil on the central surface of the white pizza increases the overall mass of the pizza from 250 to 280 g, which, given the same radiated energy, limits its temperature increase to $156 \pm 4^\circ\text{C}$ (Falciano et al., 2023b).

In tomato pizzas, the area covered with sunflower oil, being smaller than the previous one, heated up even

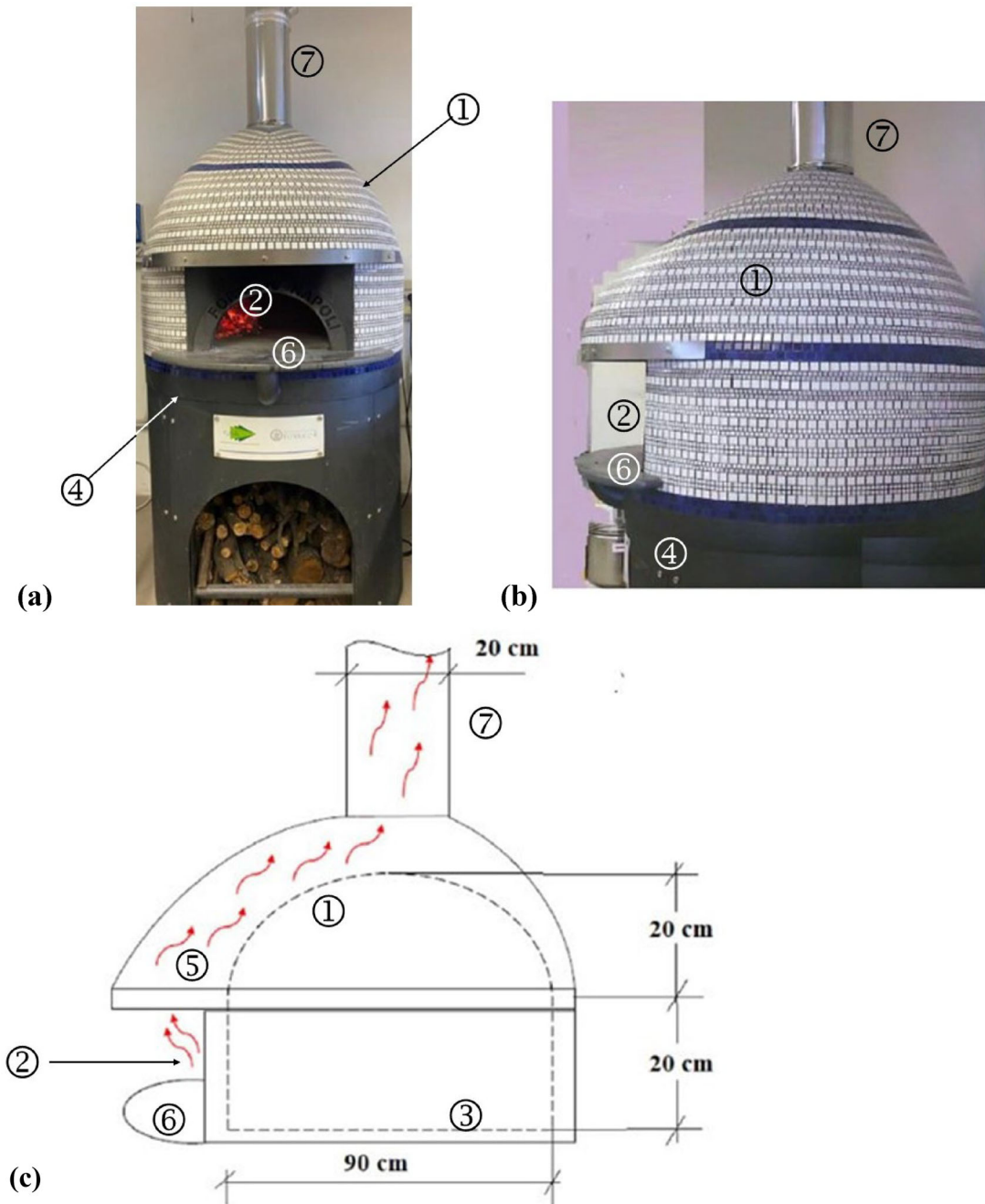

FIGURE 1 Front view (a), side view (b), and chamber geometry (c) of the wood-fired pizza oven used by Falciano et al. (2023a), with its main components labeled: (1) oven vault or dome, (2) access door, (3) oven baking floor, (4) oven base, (5) oven hood, (6) oven entry shelf, and (7) oven chimney.

less ($108 \pm 3^\circ\text{C}$), while the central area topped with tomato puree at 7 Bx, being more humid, reached a lower temperature ($81 \pm 2^\circ\text{C}$), which was not significantly different from the temperature ($84 \pm 3^\circ\text{C}$) observed in the similarly topped area of tomato pizzas enriched with oil or with oil and mozzarella (Falciano et al., 2023b). Finally, the area covered by mozzarella reached a significantly lower temperature ($67 \pm 2^\circ\text{C}$) for two reasons: (1) the initial temperature (15°C) of the mozzarella was lower

than that of the dough, tomato puree, and sunflower oil (approximately 21°C); (2) the emissivity of the mozzarella is lower than that of the tomato puree. Despite the areas of the pizza covered by different toppings reaching quite different temperatures, it was found that, on average, the weight loss due to water evaporation was about 10 g for each pizza (Falciano et al., 2023b).

In recent years, there has been extensive discussion regarding the risks associated with burnt areas on pizzas,

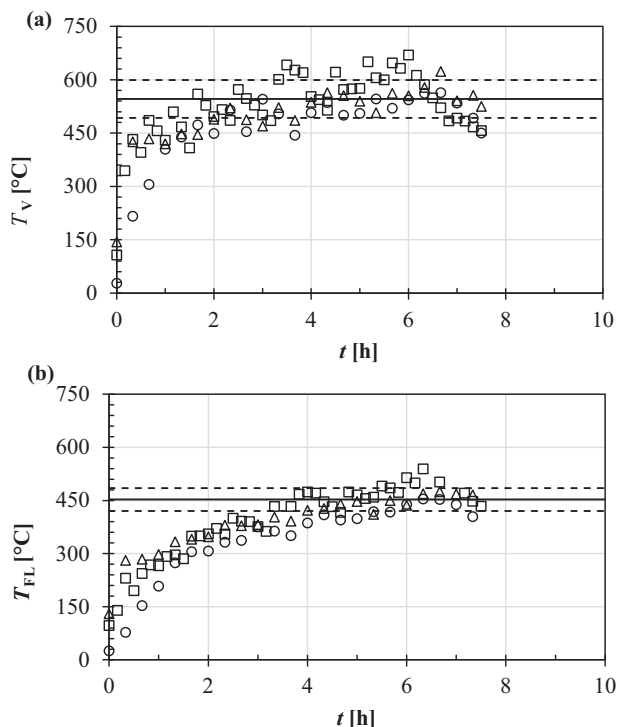

FIGURE 2 Evolution of the temperatures of the wood-fired oven dome (T_V : a) and floor (T_{FL} : b) recorded with a thermal camera by Falciano et al. (2022a) during the lighting on the 11th (□), 22nd (○), and 23rd (△) day, showing the mean value (—) and the standard deviation (— —) of the pseudo-steady state temperature, as a function of ignition time (t).

commonly linked to alleged negative health effects from ingesting carbonaceous substances or those containing acrylamide (NCI, 2017). To better quantify the formation of brown or black areas on both surfaces of the pizza, an instrument called the IRIS electronic eye was used to observe the pizzas at the end of baking (Falciano et al., 2023b). Using this equipment, each digital image was processed utilizing a spectrum of 4096 colors, each identified by three values in the RGB (red, green, and blue) space. For example, Figure 6 shows the color spectra of the upper and lower surfaces of a Margherita pizza after baking in a wood-fired oven for 80 s (Falciano et al., 2023). The extent of browning or blackening processes was evaluated by identifying the decimal codes of colors classified by the human eye as dark brown or black and thus estimating the percentage of the pizza surface that was browned or blackened.

After 80 s of baking in the wood-fired oven, the highest percentages of browning and blackening were found on the upper surface of the pizza, particularly on the crust, regardless of the toppings used (Falciano et al., 2023b). This is undoubtedly a result of the Pizzaiolo's skill in lifting and rotating the pizza with a metal peel, which not only ensures even cooking but also limits the contact of the

pizza base with the high temperature of the oven floor, thus preventing the bottom from burning. The maximum percentages of browning ($\sim 26\%$) and blackening ($\sim 8\%$) were observed in the white pizza. In pizzas topped with oil, tomato puree, and mozzarella, the browning percentages varied between 7% and 11%, while the blackening percentages were between 3% and 4% (Falciano et al., 2023b).

It is worth noting that the mentioned percentages refer to the surface area of the pizza, not the volume. A typical Neapolitan pizza has an average diameter of 28.7 ± 0.7 cm and a rim width of 2.3 ± 0.3 cm (Falciano et al., 2023b). This corresponds to overall surface areas of 623 ± 18 cm² for the pizza and 180 ± 8 cm² for the rim (Falciano et al., 2023b). On average, Marinara and Margherita pizzas weigh 350 ± 4 g and 417 ± 6 g, respectively, while the rim's weight ranges from 90 to 110 g, regardless of the toppings, as measured in a typical Neapolitan pizzeria (Falciano et al., 2022c). Under these conditions, the rim's superficial density varies between 0.49 and 0.62 g/cm². Since the burnt area of a baked pizza typically covers no more than 4% of the top surface—approximately 25 cm²—the amount of pizza to be discarded would range from 12 to 16 g, or less than 4% of the total pizza. Given that the amount of pizza typically discarded at the end of a meal in a Neapolitan pizzeria is around 6% by weight (Falciano et al., 2022c), discarding the blackened parts of the pizza, mainly the rim, does not appear to further increase food waste. Moreover, this practice could reassure those concerned about consuming charred pieces of pizza with potentially high levels of acrylamide, thus reducing the risk of developing cancer, in line with the recommendations of the European Food Safety Authority (EFSA, 2015).

3 | HEAT TRANSFER IN THE PIZZA OVEN

Cooking pizza in a wood-fired oven involves four interactive processes: wood combustion and the simultaneous transfer of heat, matter, and momentum. As the wood logs burn in a specific area of the oven floor, they release combustion heat and form the flame. Air naturally enters through the open mouth of the oven to feed the fire, while the combustion gases formed are expelled through the chimney.

Pizza cooking occurs through three heat transfer mechanisms (conduction, convection, and radiation), as illustrated in Figure 7.

Heat transferred by conduction (Q_{cond}) is governed by Fourier's law and is directly proportional to the surface area of the pizza in contact with the oven floor (A), the thermal conductivity of the dough ($k \approx 0.5$ W/m/K), and the difference between the temperature of the oven floor (T_{FL} ,

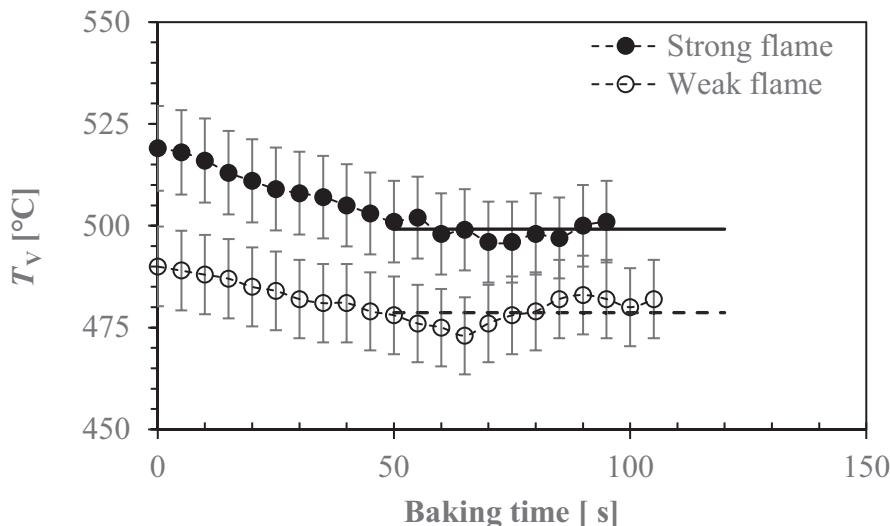

FIGURE 3 Evolution of the dome temperature (T_V) in the wood-fired oven depicted in Figure 1, recorded with a thermal camera, as a function of the baking time of Margherita pizza, varying with flame intensity (strong or weak), and showing the mean values (—; - -) of the dome temperature at the end of baking.

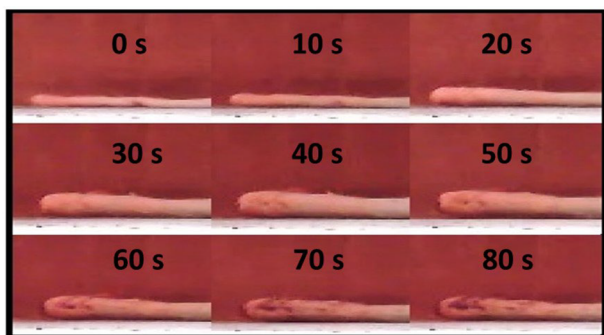

FIGURE 4 Photos of the cross-section of a pizza base topped with tomato sauce and sunflower oil at different cooking times ranging from 0 to 80 s, as extracted from Falciano et al. (2023b).

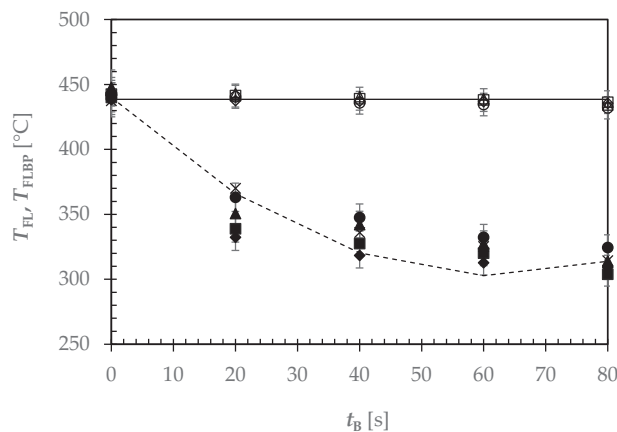

FIGURE 5 Effect of baking time (t_B) on the average temperatures of the oven floor exposed to the fire (T_{FL} : empty symbols; +) or shielded by the pizza (T_{FLbp} : closed symbols, X) as determined by Falciano et al. (2023b) during the baking tests of various types of pizza: white: \circ , \bullet ; white with oil: \triangle , \blacktriangle ; tomato: \square , \blacksquare ; tomato with oil: \diamond , \blacklozenge ; tomato with oil and mozzarella: +, X. The solid horizontal line indicates the average temperature of the oven floor around any pizza during baking, whereas the broken line represents the temperature profile of the oven floor covered by a tomato pizza.

which decreases from 450°C to 330°C; see Figure 5) and that of the pizza itself ($T_S \approx 100^\circ\text{C}$). Q_{cond} is also inversely proportional to the thickness of the pizza base ($s \approx 2.5\text{ mm}$):

$$Q_{\text{cond}} = \frac{k}{s} A (T_{\text{FL}} - T_S) \quad (1)$$

Under these conditions, the conductive heat flux would range between 46 and 70 kW/m².

Heat transferred by convection (Q_{conv}) is due to the natural convective motion that occurs within the oven chamber, causing the mixing of incoming air from outside with combustion fumes. This mixture brushes against the hot oven walls and the pizza being baked, stabilizing the temperature and humidity level within the oven chamber. Q_{conv} is described by the Nusselt law and is directly proportional to the surface area of the top of the pizza (A),

which is approximately equal to that of the bottom, the convective heat transfer coefficient of the hot gases ($h \approx 9\text{--}18\text{ W/m}^2/\text{K}^1$) (Falciano, et al., 2023a), and the difference between the temperature of the hot gases (T_c) and the pizza (T_S):

$$Q_{\text{conv}} = h A (T_c - T_S) \quad (2)$$

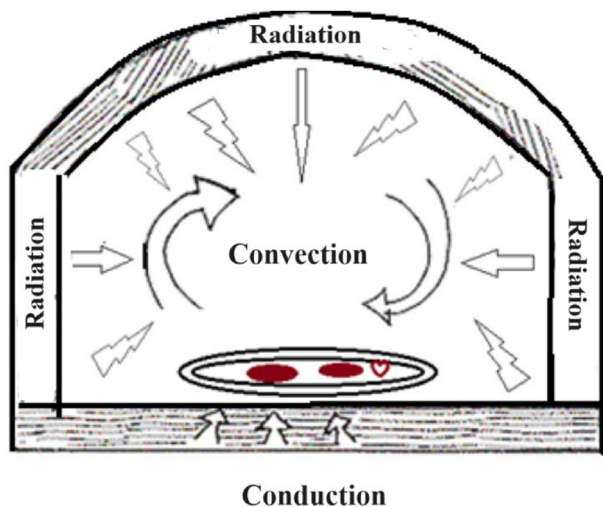

FIGURE 7 Mechanisms of heat transfer in a pizza oven.

body (T_{Kc}) and the pizza (T_{KS}):

$$Q_{\text{rad}} = \frac{1}{\frac{1}{\varepsilon_c} + \frac{1}{\varepsilon_s} - 1} A \sigma (T_{Kc}^4 - T_{KS}^4), \quad (3)$$

where σ ($=5.67 \times 10^{-8} \text{ W/m}^2/\text{K}^4$) indicates the Stefan-Boltzmann constant, while ε_c and ε_s represent the emissivities of the hot body (for refractory brick, it ranges between 0.80 and 0.94) (Jones et al., 2019) and the cold body (for pizza, it is around 0.85: Ciarmiello & Morrone, 2016b). In this case, the temperature of the hot bodies (gases and refractory bricks) will be close to that of the oven dome (which on average will be 484°C or 509°C : see Figure 3), resulting in a radiative heat flux of 13–15 kW/m^2 .

In a heating test in a wood-fired oven using an aluminum tray filled with water (Falciano et al., 2023a) the total power transferred to the water amounted to $1.49 \pm 0.03 \text{ kW}$ and was primarily due to radiative flux ($72.5 \pm 0.9\%$), followed by convective flux ($15.5 \pm 0.3\%$) and conductive flux ($12.0 \pm 0.6\%$). In this test, the contribution of the conductive flux was significantly lower than previously mentioned, because the heat absorbed by the base of the pizza, when placed on the hot oven floor, caused an almost instantaneous evaporation of part of the water content, forming a laminar film of stagnant air and water vapor with a heat transfer coefficient of approximately $9 \text{ W/m}^2/\text{K}$ (Falciano et al., 2023a). Under these conditions, the aforementioned conductive flux would vary from 2.1 to 3.2 kW/m^2 .

Regarding the thermal balance of a wood-fired pizza oven operating under pseudo-steady-state conditions, Falciano et al. (2023a) estimated that 46% of the thermal power generated by burning firewood was dissipated with the exhaust gases, whereas 15% and 11% were, respectively, lost from the outer surfaces of the oven walls and floor to

the surrounding environment through radiation and convection. The remaining 28% was stored in the refractory bricks of the oven (Falciano et al., 2023a).

To limit thermal losses from the oven, the dome, walls, and floor are constructed with refractory materials capable of withstanding high temperatures without deforming or melting. Red refractory bricks can withstand temperatures up to 1050°C , while those made with high alumina content can endure up to 1300°C . Importantly for cooking, these materials conduct heat very effectively: their thermal conductivity, ranging from 1.63 to $1.70 \text{ W m}^{-1}\text{K}^{-1}$, respectively, is 10–100 times higher than insulating materials like rock or glass wool ($0.04 \text{ W m}^{-1}\text{K}^{-1}$), but about 30 times lower than that of steel ($45 \text{ W m}^{-1}\text{K}^{-1}$) (The Engineering ToolBox, 2003). This difference in thermal properties between refractory bricks and steel results in greater thermal inertia of the former compared to steel, meaning they are less prone to rapid temperature changes in response to external temperature variations. In other words, during pizza baking, the temperature of refractory bricks changes slowly, and the oven remains in approximately steady conditions even after several hours of operation. On the other hand, using steel plates for the oven floor would cause their temperature to decrease more quickly when in contact with the pizza, requiring periodic stops during operation to allow the plate to return to the optimal temperature, as commonly needed for gas-fired ovens.

The ovoid shape of the oven promotes the mixing of incoming air and combustion gases in the oven chamber. If a wood-fired or gas oven had a rectangular or square section instead, the corner zones farthest from the flame would reach significantly lower temperatures compared to the central areas, resulting in uneven baking of the pizza (Ciarmiello & Morrone, 2016b). Rectangular or square sections are more suitable for electric ovens because the use of evenly distributed Ni-Cr resistance elements across the cooking surface and the ceiling allows for almost uniform heating of both the baking surface and the ceiling, including the areas at the corners of the oven.

Overall, the average thermal efficiency of the pilot wood-fired oven during tests involving heating water or baking differently topped pizzas (white or tomato-based) was found to be approximately $13 \pm 4\%$ (Falciano et al., 2022a; 2023a).

4 | TYPES OF PIZZA OVENS

Having analyzed the phenomenology of the pizza baking process in a typical wood-fired oven, as outlined in EU Regulation No. 97/2010, the question arises whether alternative gas or electric ovens can match the results achieved with wood-fired ovens. To answer this question,

various factors need to be considered, such as the oven's ability to reach and maintain the necessary temperatures for uniform and rapid pizza baking, the even distribution of heat, and the ability to impart that characteristic smoky flavor typical of wood-fired baking. To this end, the main types of pizza ovens currently available on the market, from traditional wood-fired ovens to new gas or electric models, will be analyzed.

4.1 | Wood-fired ovens

As highlighted in the online catalogs of various wood-fired pizza oven manufacturers, such as Alfa Forni Srl (<https://pro.alfaforni.com/it/>), Di Fiore Forni snc (<https://www.difioreforni.com/collections/forni-per-pizzerie>), Marana Forni Srl (<https://www.maranaforni.it/>), Pavesi Srl (<https://www.pavesiforni.it/>), Starpizza (www.starpizza.org), Stefano Ferrara Forni Srl (<http://www.stefanoferraraforni.it/it/>), and Valoriani Srl (<https://valoriani.it/forni/>), the basic structure of these ovens has remained largely unchanged in recent years. However, modern ovens now utilize more efficient refractory and insulating materials, improving their performance compared to earlier models.

Referring to Figure 1, the traditional wood-fired oven is essentially composed of the following components:

1. *Vault*: a dome built with refractory bricks designed to retain and optimally maintain heat while resisting the high temperatures that occur inside it. It is generally spherical or ellipsoidal in shape.
2. *Access door* (mouth): it is kept open to allow the Pizzaiolo to check the pizza's cooking and add more wood logs to maintain a temperature close to 400°C inside the chamber. The height of the mouth is approximately 60% of the height of the dome, which represents a good compromise to limit heat loss to the outside and evenly heat inside of the oven.
3. *Baking floor*: this is where the pizzas are placed inside the oven to cook. It is made of highly resistant refractory material to withstand the wear from oven use and the friction from the peel used to turn the pizza during cooking and the tools used to clean it from inevitable crusting.
4. *Base*: it is essential for optimizing the work of the oven and the Pizzaiolo. Therefore, the baking floor of the oven is positioned about 90 cm from the ground. The base also limits the thermal dispersion of the cooking floor and consequently the wood consumption.
5. *Hood*: its function is to prevent combustion fumes from stagnating inside the oven and exiting through the mouth, invading the surrounding environment.

This requires that the fume extraction ducts are of appropriate size without bends or section reductions to limit pressure losses and facilitate the evacuation of fumes outside the building.

Controlling the temperature inside the oven is crucial to avoid burning the pizza if it is too high, or undercooking the pizza in the center if it is too low. To this end, the Pizzaiolo relies either on acquired expertise or an infrared laser thermometer.

When selecting a wood-fired oven, several key technical specifications are typically required, as highlighted in various online catalogs:

1. The oven dimensions, which should align with the specific needs of the pizzeria and are generally determined by the diameter of the baking floor.
2. The number of pizzas that can be simultaneously placed on the baking floor.
3. The time required to bring the oven to baking temperature.
4. The maximum temperature the oven can achieve.
5. The wood consumption rate.

The choice of the oven can fall into two categories:

1. Ovens built entirely on-site,
2. Prefabricated ovens.

Both types are widely used in Italy; although currently, prefabricated ovens, made with preassembled refractory material blocks, are the most common. The key difference between these two oven types lies in the complexity of construction. Prefabricated ovens are easier to install and accessible to anyone with minimal manual skills, whereas the construction of a brick oven requires specific expertise and increases the cost of realization. On the other hand, their maintenance is less expensive, as individual bricks can be easily replaced without having to change the entire block, as is the case with a prefabricated oven.

Referring to the online catalogs of the aforementioned wood-fired pizza oven manufacturers, Figure 8 presents the schematic plan of a generic wood-fired pizza oven, whereas Table 1 details the main characteristics of such ovens. These characteristics include the internal diameter (A) and external diameter (B) of the baking floor, the depth (C) including the width of the entry shelf, the overall height (H) of the oven, the overall weight, wood log fuel rate (Q_{fw}), and thermal power (TP). The ovens are classified by the number of pizzas (ranging from 2 to 15) that the baking floor can accommodate.

After analyzing the data in Table 1, a proportionality in the main geometric dimensions of wood-fired ovens

TABLE 1 Main characteristics [oven internal (A) and external (B) diameters of the baking floor; depth (C) and overall height (H); overall weight (OW); wood log fuel rate (Q_{fw}); thermal power (TP)] of various wood-fired ovens available on the market with a capacity of 2–15 pizzas (30-cm diameter).

| Capacity (Pizza no.) | A (cm) | B (cm) | C (cm) | H (cm) | Oven weight (kg) | Q_{fw} (kg/h) | TP (kW) |
|-------------------------|-----------|-----------|-----------|-----------|---------------------|--------------------|------------|
| 2 | 75–80 | 110–150 | 130–150 | 170–204 | 350–1500 | | |
| 3 | 90 | 120–135 | 150–160 | 205 | 1200–1700 | | 15 |
| 4 | 100–110 | 138–140 | 152–178 | 180–205 | 900–1900 | | 15 |
| 5 | 110–120 | 148–150 | 160–188 | 185–210 | 1100–2200 | | 34 |
| 6 | 130 | 160–175 | 180–200 | 213 | 1450–2500 | | 34 |
| 7 | 140 | 210 | 210 | 215 | 2800 | | |
| 8 | 130–150 | 160–180 | 185–220 | 185–216 | 1325–3000 | | 34 |
| 9 | 129 | 165 | 180 | 192 | 1700 | 5 | |
| 10 | 150 | 188 | 208 | 185 | 1800 | | |
| 12 | 147 | 190 | 200 | 192 | 2000 | 6 | |
| 15 | 180 | 220 | 240 | 203 | 2800 | | |

Note: Data were retrieved from the online catalogs of the wood-fired pizza oven manufacturers mentioned in the text.

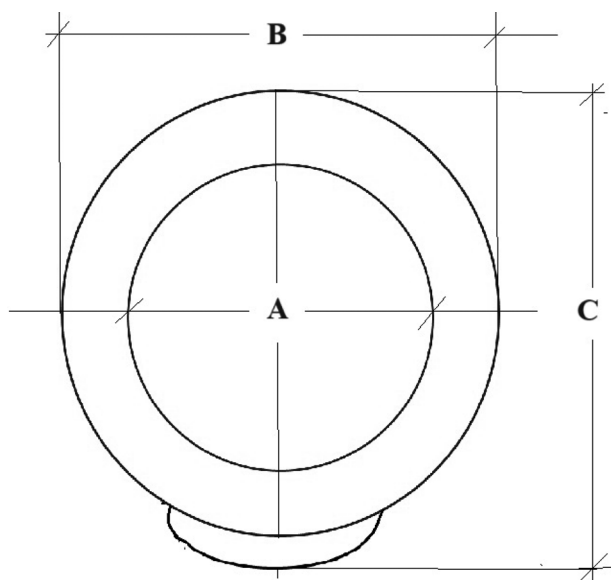

FIGURE 8 Schematic plan of a wood-fired pizza oven highlighting the internal (A) and external (B) diameters of the baking floor, as well as the depth (C), including the entry shelf, of the oven. This plan has been redrawn based on the online catalogs of the wood-fired pizza oven manufacturers mentioned in the text.

was observed as the number of pizzas that can be baked simultaneously varied, whereas the same does not apply to their total weight, probably due to their different insulation.

A new type of wood-fired oven with a rotating baking floor has also been introduced, which is present in the catalogs of some Italian oven manufacturing companies such as Di Fiore Forni snc, Marana Forni Srl, Pavesi Srl, Valoriani Srl, and others. The rotating cooking floor offers

the Pizzaiolo greater ease and productivity during baking. Thanks to its rotational movement; once cooked, the pizza is automatically positioned at the oven's exit, ready to be removed and served. This way, the space previously occupied is freed up for the next pizza to be cooked. However, with this system, the Pizzaiolo cannot manually rotate the pizza while it is on the cooking floor, which surely increases the percentage of browned and blackened areas on the pizza bottom. The rotation mechanisms are safely placed away from the flame and embers, and the rotation speed of the floor is controlled via an external panel. For ovens with a capacity of 9–12 pizzas, the motor to be installed has a power of 0.5 kW (<https://www.pavesiforni.it/wp-content/uploads/2022/08/Catalogo-General-Pavesi-ITA-2021.pdf>; accessed August 25, 2024).

The use of a traditional wood-fired oven requires considerable manual skill not only to light it but also to maintain it in a stable operating condition by continuously feeding it with wood. This expertise is often underestimated by most people but represents one of the most critical aspects within a pizzeria with a wood-fired oven. It is an art that has been recognized as an integral part of the Neapolitan Pizzaiolo tradition and as an intangible cultural heritage of humanity by UNESCO (2017).

A critical review of the wood-fired pizza ovens mentioned in the text and described online highlights several significant challenges associated with their use:

1. Approximately one-third of the oven's internal space is occupied by the wood required for combustion.
2. The soot produced during combustion must be managed with specific abatement devices, and the resulting fumes need to be properly vented upward.

3. Because the heat source is positioned on one side, the operator must frequently move and rotate the pizzas to prevent burning.
4. The oven structure is notably heavy (Table 1).
5. Temperature control within the oven depends entirely on the Pizzaiolo's skill, requiring them to gauge temperature variations by touch or with infrared laser thermometers, a technique refined through years of experience.

Wood-fired ovens are widespread worldwide, used in restaurants, rotisseries, and bakeries. For example, in the city of São Paulo, Brazil, there are approximately 6400 pizzerias with wood-fired ovens consuming about 48 metric tons (Mg) of wood per year. However, the use of these ovens results in high emissions of fine particulate matter (PM_{2.5}). For every kilogram of wood burned, an average emission factor of around 0.38 g of PM_{2.5} was estimated by Lima et al. (2020).

The average PM_{2.5} concentrations measured at chimney outlets are quite high (6171 µg/m³), whereas indoors they are at least two orders of magnitude lower (68 µg/m³) (Lima et al., 2020). These concentrations significantly exceed the levels recommended by the World Health Organization, which are 15 µg/m³ over a 24-h period (WHO, 2022). In response to this issue, some places such as Delhi in India and the Municipality of San Vitaliano near Naples (Italy) have implemented measures to reduce emissions, either by banning or regulating the use of wood-fired ovens in restaurants and bakeries during the winter season or by mandating the installation of pollution control filters on chimneys (Apurva, 2016; Singh & Highway, 2016).

It is important to note that the New York City Department of Environmental Protection approved legislation as early as 2016 aimed at cutting emissions of fine particulate matter by up to 75% from wood- and coal-fired ovens and stoves (New York City Administrative Code, 2016). This law was originally scheduled to take effect by January 2020 but was postponed due to the spread of the COVID-19 pandemic, with enforcement now slated to begin on April 27, 2024 (Nierenberg, 2024).

As a result, it will become mandatory to install adequate soot abatement systems. These consist of a washing tower where the fumes from the oven are treated with high-pressure water sprays. The suspended particles in the fumes absorb water, becoming heavier and settling into the purifier tank to be disposed of with wastewater. Thanks to these devices, it is possible to neutralize up to 98% of suspended particles and up to 50% of odors resulting from combustion (<https://www.abbattitorizapper.it/abbattitori-di-fumi/zpz/>; accessed August 25, 2024). Currently, there are numerous models available capable of treating from 200 to 14,000 m³/h of combustion fumes, using centrifugal

pumps with rated power ranging from 0.75 to 2.2 kW, primarily fed with recycled water (<https://etcgroupsrl.it/en/ah250-abbattitori-di-fuliggine>; accessed August 25, 2024). The investment cost varies depending on the type of abatement system, from €250 for pellet stoves to €3000 for a restaurant kitchen (https://eterra.it/abbattitori-di-fuliggine/?expand_article=1&utm_content=cmp-true; accessed August 25, 2024). The installation of these abatement systems offers a clear advantage by limiting the accumulation of soot in chimney flues. By improving draft and combustion efficiency, it reduces fuel waste and the risk of chimney fires and explosions.

4.2 | Gas ovens

Gas ovens have a structure very similar to traditional wood-fired ovens. Many models allow for both wood-fired and natural gas or liquefied petroleum gas (LPG) operation, as highlighted in the online catalogs of various Italian manufacturing companies such as Alfa Forni Srl (<https://www.alfaforni.com/it/>), MAM Forni (<https://www.mamforni.it/>), Marana Forni Srl (<https://www.maranaforni.it/>), Morello Forni Italia Srl (<https://www.morelloforni.com/it/>), Pavesi Srl (<https://www.pavesiforni.it/en/home/>), Stefano Ferrara Forni (<https://www.stefanoferraraforni.it/>), Refrattari Valoriani Srl (<https://valoriani.it/>), and others. By consulting the online catalogs of the aforementioned pizza oven manufacturers, it was possible to create a schematic drawing of the front and top views of a typical gas oven (see Figure 9). This oven not only shares the same components as a wood-fired pizza oven (Figure 1), but is also equipped with the following specific features:

1. Burners: located inside the cooking chamber, occupying at least 30% of the total area; these produce a flame like that of wood-fired ovens. Combustion gases with various residues are expelled through the chimney; however, the soot produced by the flame tends to deposit on the internal walls of the oven and could fall onto the pizza during cooling or when the oven temperature decreases.
2. Gas burner cutout: a safety device or mechanism that automatically shuts off the gas burner in certain situations, such as when the flame goes out unexpectedly or when there is a malfunction.
3. Control panel: typically positioned outside the oven, it allows for adjusting both the flame intensity and the internal temperature of the chamber.

Based on the reinterpretation of the online catalogs of the aforementioned gas pizza ovens, the main advantages of gas ovens can be summarized as follows:

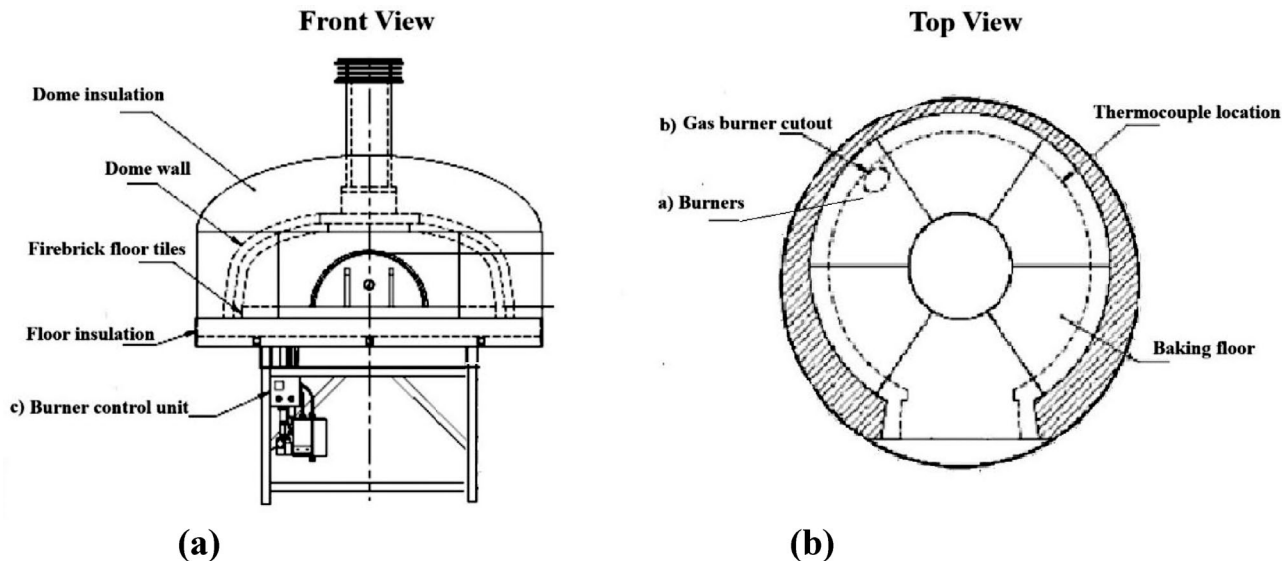

FIGURE 9 Front view (a) and top view (b) of a typical gas pizza oven, freely reinterpreted from the online catalogs of the pizza oven manufacturers mentioned in the text, with its main components labeled: a) burners, b) gas burner cutout, and c) burner unit control.

1. Ease of use: Ignition and shutdown are achieved by simply operating a switch.
2. Lower fuel consumption: Thanks to the higher calorific value of natural gas (35.8 MJ/m³) or LPG (45.5 MJ/kg) compared to firewood (17 MJ/kg); gas ovens generally have lower fuel consumption than wood-fired ovens.
3. Simplified cleaning: The use of natural gas or LPG minimizes chimney cleaning issues, as there is no need for filters to reduce fine particulate matter.

However, there are also some disadvantages:

1. Higher operating costs: In addition to the higher initial investment, operating costs for gas ovens are usually higher compared to wood-fired ovens. This is due to the higher specific cost of natural gas or LPG compared to firewood, without significant compensation through lower fuel consumption rate (cf. §5.).
2. Difficulty in maintaining optimal baking temperatures: Despite having a masonry structure like wood-fired ovens, gas ovens struggle to maintain the appropriate cooking chamber temperatures for optimal baking. In the absence of radiant heat from the embers at around 850°C, which normally also conducts heat to the oven floor, the temperature for baking pizza is generally lower than that achieved in wood-fired ovens. Furthermore, after several bakes, the temperature of the oven floor tends to decrease, compromising even baking of the pizza rim. To restore the optimal floor temperature, it is necessary to pause inserting pizzas for baking. Even with increased gas flow, the oven takes time to return to optimal baking temperatures. Therefore, pizza makers

require skill in managing baking temperatures. One solution to this issue is the *Recycling Heating System*[®], patented by Refrattari Valoriani Srl, which heats the oven floor by circulating combustion gases beneath it (<https://valoriani.it/catalogo/rotativo-gas-legna/>; accessed August 25, 2024).

3. Longer cooking times: The average cooking time for pizza in a gas oven is longer compared to that in a wood-fired oven, leading to increased evaporation and reduced pizza moisture content, thereby limiting its softness and ability to roll without breaking.

4.3 | Electric ovens

Italian manufacturing companies, such as Forni DAVID Srl (<https://www.fornidavid.it/en/pizza-ovens/>), Italforni SpA (<https://www.italforni.it/en/2021/06/28/commercial-electric-oven/>), MAM Forni (https://www.mamforni.it/wp-content/uploads/2024/06/2024_MAMforniCatElet_ItaEng.pdf), and Refrattari Valoriani Srl (<https://maximo.valoriani.it/en/home-en/>), frequently highlight electric ovens in their online catalogs that feature multiple independent cooking chambers. This design allows for faster pizza production by enabling simultaneous cooking in separate compartments. In professional models, these chambers are typically lined with refractory materials, ensuring they can withstand high temperatures and deliver optimal performance.

The heat source consists of stainless-steel heating elements integrated into the refractory of the cooking floor and dome, enabling precise temperature control.

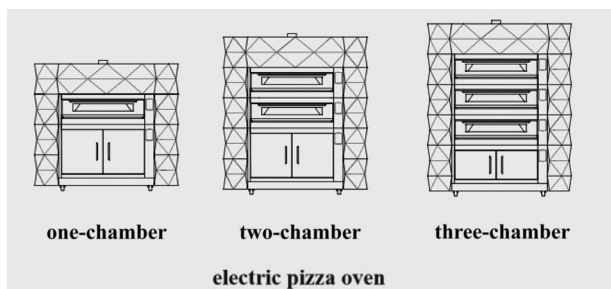

FIGURE 10 Front view of a one-, two-, or three-chamber electric pizza oven, with each chamber having uniform dimensions of 17 cm in height, 105 cm in width, and 105 cm in depth, freely reinterpreted from the modular diamond electric pizza oven model manufactured by Italforni SpA (<https://www.italforni.it/src/uploads/2021/09/catalogo-DIAMOND-WEB.pdf>).

Key parameters for evaluating an electric oven include maximum achievable temperature, oven size, energy consumption, and the time required to reach stable thermal conditions.

A critical review of the electric pizza ovens discussed in the text revealed that the quality of pizza baking was reflected in several key factors:

1. Uniform cooking achieved by minimizing temperature variations across different zones of the oven.
2. Modularity by separately adjusting the temperatures of the oven floor and dome, ensuring consistent and stable cooking while optimizing energy consumption.

The use of an electric oven is also facilitated by numerous pre-set functions and automatic temperature management, as well as reduced maintenance and ease of cleaning. The average thermal power used by electric ovens varies by model. For instance, Figure 10 shows a schematic drawing of electric models with single, double, or triple chambers that can simultaneously cook 9, 18, or 27 pizzas with a 33-cm diameter at temperatures up to 450°C. The overall weight of these models increases progressively from 480 to 740 kg and 1000 kg, respectively. This capability is made possible by groups of three-phase electric heating elements, powered at an alternating voltage of 400 V at 50 Hz, capable of delivering a maximum power of 12, 23, or 34 kW, with an average consumption of approximately 6, 12, or 17 kWh, respectively (<https://www.italforni.it/src/uploads/2021/09/catalogo-DIAMOND-WEB.pdf>; accessed August 25, 2024). Unlike traditional wood-fired ovens, modular electric ovens with multiple chambers offer the ability to simultaneously cook a greater number of pizzas, reduce specific energy consumption, and facilitate the amortization of the investment made.

A critical analysis of online catalogs for electric pizza ovens highlights a general emphasis on optimizing energy efficiency by enhancing the oven's thermal insulation to minimize heat loss. Additionally, many manufacturers offer techniques for energy savings, including standby modes, heat management strategies, and rapid heating technologies. The purchase cost of an electric oven should be directly requested from each manufacturer, as it is expected to vary based on factors such as material quality, brand, size, and available features.

It is widely recognized that electric pizza ovens provide several advantages over wood-fired models, such as consistent cooking, ease of use, and simpler cleaning. Furthermore, the lack of firewood consumption eliminates issues related to transportation, as well as the disposal of ashes and combustion residues (Falciano et al., 2022c). Moreover, installing a photovoltaic system can further lower energy consumption and take advantage of available state incentives. It is also noteworthy that Furlanis (2017) from the Academy of Pizzaioli emphasized these points by comparing the two types of ovens:

1. Adjusting the electric heating element placed under the cooking surface prevents cooling at the pizza support point. This issue is common in wood-fired ovens due to interrupted radiation and heat absorption caused by pizza moisture evaporation.
2. There is no need for transporting and storing firewood, keeping premises clean without sawdust or ashes.
3. Installing an electric oven is easier compared to a wood-fired one, which requires a masonry structure, good ventilation, and a chimney. In some cases, installing a chimney can be impossible. Moreover, the electric oven does not necessitate a hood and vent, required only in specific instances by Local Health Authorities.

Considering the issues highlighted regarding the high emission of fine particles associated with the use of wood-fired ovens, the AVPN (2020) acknowledged this environmental impact. Following a rigorous validation process of the quality of the pizza obtained, conducted by the Association's Directive Board and industry experts, AVPN approved in 2020 and included in its Register of Qualified Suppliers an innovative electric oven called *Scugnizzonapoletano*. This oven, conceived and designed in Naples by Engineer Giuseppe Krauss and manufactured by Scugnizzo Napoletano Srl of Naples, represents a milestone as the first electric oven capable of recreating the baking conditions necessary to achieve true Neapolitan pizza, in accordance with the parameters established by AVPN's regulations. This approval provides a significant alternative to obtaining AVPN certification without necessarily resorting to the use of a wood-fired oven.



FIGURE 11 Images of the 10 electric pizza ovens described in Table 2.

The *Scugnizzonapoletano* electric oven features the same dome shape as traditional wood-fired ovens (see Figure 11h), thus reproducing the convective movements of hot gases and reaching ideal temperatures for preparing true Neapolitan pizza (450°C–470°C). The Ni–Cr resistance elements are differentiated between the floor and the dome of the oven, allowing independent control of power and timing through a control panel with 10 levels of settings for both areas. Overall, the oven's shape, the oven floor made of clay and volcanic sand with a porous structure (known as *biscotto di Sorrento*), and the uniform heat distribution through conduction, convection, and radiation mechanisms ensure perfect cooking in just 1 min and the typical coloring of Neapolitan pizza, just like in a traditional wood-fired oven. However, members of the *Associazione Pizzaioli Napoletani* maintain a skeptical attitude toward the use of electric ovens, believing that true Neapolitan pizza should be exclusively baked in a traditional wood-fired oven (Fucito, 2020).

Currently, at the request of pizza oven manufacturers, the AVPN has certified 10 different models of electric pizza ovens. The main technical specifications for these models were extracted from online catalogs and are summarized in Table 2. For the geometric dimensions A, B, and C, please refer to the schematic plan in Figure 8. The images of these models are illustrated in Figure 11.

With slight variations, all ovens shown in Figure 11 share the typical dome structure of traditional wood-fired ovens and have substantially similar nominal energy consump-

tion. Among these, the Augusto oven produced by Dr. Zanolli Srl features an innovative patented system called *Air Trap System*[®] (<https://zanolli.it/prodotti/avgvsto/>). During baking, this system creates a recirculation of hot gases inside the oven chamber, helping to form a barrier near the oven opening. This process minimizes heat loss, a common characteristic in dome ovens with an open mouth. It facilitates the work of the pizza maker by preventing hot gas from escaping during pizza loading. Detailed information on the distribution of electric resistances in the floor and dome of each oven is not commonly available, except for the Maximo electric pizza oven developed by Refrattari Valoriani Srl (<https://valoriani.it/catalogo/forno-per-pizza-elettrico/>; accessed on August 25 2024). This oven has a capacity of seven pizzas with a 30-cm diameter, a nominal power of 16 kW, and an average consumption of 6–12 kWh. Although not AVPN-certified, this oven is noteworthy for several reasons:

1. It uses electric resistances arranged in star-shaped radial bundles at the top of the dome. These resistances, operating at a red-hot glow, are designed to emulate the radiation of flames in traditional wood-fired ovens.
2. It features a patented system for recirculating hot gases called *RHS*[®] *Evolution*. This system injects steam to keep constant relative humidity inside the baking chamber, enhancing the fragrance and texture of the pizza.

TABLE 2 Main technical specifications of AVPN-certified and -approved electric pizza ovens (<http://www.pizzanapoletana.org/it/fornitori>; accessed August 10, 2024), with their images illustrated in Figure 11.

| Company | Model | Image | Capacity | A (m) | B (m) | C (m) | Power (kW) | Weight (kg) |
|---|----------------------|------------|--|------------------------------|------------------------------|------------------------------|-----------------------------|--------------------------|
| Esmach Ali Group Srl (www.esmach.com/it/) | Bake Stone® | Figure 11a | 4 pizzas (Ø 45 cm) 7 pizzas (Ø 35 cm) | nd | 1.49 | 1.55 | 16.3 | 416 |
| Stefano Ferrara Forni (www.stefanoferraraforni.it/) | Gennarino | Figure 11b | 3 pizzas 4 pizzas 5 pizzas | 0.8 1.0 1.2 | 1.13 1.33 1.53 | 1.40 1.65 1.95 | 9.6 11.0 16.0 | 480 600 800 |
| Italforni Pesaro Srl (www.italforni.it/) | Caruso® | Figure 11c | 6 pizzas (Ø 35 cm) 9 pizzas (Ø 35 cm) | 0.49 | 0.75 | 0.96 | 13.2 20.5 | 230 320 |
| Izzo forni srl (https://izzoforni.it/i-nostri-forni/) | Izzonapoletano | Figure 11d | 2 pizzas (Ø 33 cm) 4 pizzas (Ø 33 cm) 6 pizzas (Ø 33 cm) 9 pizzas (Ø 33 cm) | 0.49 0.75 0.75 1.03 | 0.75 1.10 1.10 1.45 | 0.96 1.03 1.35 1.51 | 8.5 11.7 13.3 16.5 | 330 480 580 880 |
| Manna Forni Srls (www.mannaforni.com/it/) | Masaniello | Figure 11e | nd | nd | nd | nd | nd | nd |
| MP Forni Srl (mpforni.it/prodotti/forno-elettrico/) | Diamante Italiano | Figure 11f | 7 pizzas (Ø 33 cm) | 1.00 | 1.48 | 1.65 | 15 | 470 |
| Resto Italia® (www.restoitalia.it/) | Cratos | Figure 11g | 9 pizzas (Ø 30 cm) | 0.93 | 1.60 | 1.64 | 15.3 | 510 |
| Scugnizzo Napoletano Srl (https://scugnizzonapoletano.eu/modelli/) | Scugnizzo-napoletano | Figure 11h | 4 pizzas (Ø 33 cm) 6 pizzas (Ø 33 cm) 9 pizzas (Ø 33 cm) | 0.75 0.75 1.03 | 1.03 1.10 1.45 | 1.10 1.35 1.51 | - - - | 480 580 880 |
| SudForni Srl (https://sudforni.it/) | Opale | Figure 11i | 5 pizzas (Ø 33 cm) 7 pizzas (Ø 33 cm) 9 pizzas (Ø 33 cm) | 0.87 1.14 1.22 | 1.30 1.60 1.80 | 1.45 1.70 1.85 | 14 17 20 | 500 700 900 |
| Dr. Zanolli Srl (https://zanolli.it/prodotti/avgvsto/) | Augusto | Figure 11j | 6 pizzas (Ø 33 cm) 9 pizzas (Ø 33 cm) | 1.04 1.04 | 1.62 1.91 | 1.80 2.12 | 14.4 19.2 | 455 550 |

Abbreviation: nd, not determined.

5 | ENERGY CONSUMPTION OF PIZZA OVENS

To evaluate the energy consumption of three commercial types of pizza ovens, four models were examined: wood-fired, natural gas, LPG, and electric ovens, each with a maximum capacity of six pizzas of 33 cm in diameter.

For the wood-fired oven, an average market price of €0.15–0.5/kg for certified oak logs was considered. For the gas ovens, both natural gas and LPG were analyzed, with current specific costs of €0.8–1.2/m³ for natural gas and €2.00–2.30/kg for LPG. Finally, for the electric oven, a cost of €0.30–0.38/kWh was considered.

Table 3 shows the fuel consumption rates and operating costs of the four examined pizza ovens. The highest operating cost is associated with the LPG oven, while the operating costs for natural gas and electric ovens range between €2.10 and €4.10 per hour, depending on the supply contract chosen. If the cost of firewood remains at €0.15/kg, using the wood-fired oven proves to be the

most economical option. This supports the perspective of traditionalists who prefer to strictly adhere to the true Neapolitan pizza guidelines. Natural gas and electric ovens offer competitive operating costs, making them viable alternatives depending on fuel prices and availability.

6 | RECOMMENDATIONS AND CONSIDERATIONS FOR PIZZA OVEN SELECTION

This study conducted an in-depth analysis of the Neapolitan pizza cooking process using a pilot wood-fired oven under pseudo steady-state conditions. Key findings included temperature variations during baking and the influence of toppings on temperature distribution.

Although the European Commission Regulation No. 97/2010 mandates the exclusive use of wood-fired ovens for cooking True Neapolitan Pizza, environmental concerns about fine particle emissions have prompted the

TABLE 3 Estimated specific fuel or energy consumption rates and operating costs of different types of pizza ovens with a capacity of six pizzas.

| Oven type | Model | Max power (kW) | Unit | LHV ^a (MJ/unit) | Density (kg/L) | Consumption rate (Unit/h) | Specific cost (£/unit) | Operating cost (€/h) |
|-------------|--------------------------------|----------------|----------------|----------------------------|----------------|---------------------------|--------------------------------------|----------------------|
| Wood-fired | Stefano Ferrara-Classico 130 | 29 | kg | 17 | 0.7 | 6.14 | 0.15 ^b –0.50 ^c | 0.92–3.07 |
| Natural gas | Stefano Ferrara-Classico 120 G | 34 | m ³ | 35.8 | 0.00072 | 3.42 | 0.80–1.20 ^d | 2.74–4.10 |
| LPG | Stefano Ferrara-Classico 120 G | 34 | kg | 45.5 | 0.537 | 2.69 | 2.00–2.30 ^e | 5.38–6.19 |
| Electric | Izzonapoletano IZ6 | 13.3 | kWh | – | – | 8.5 | 0.33–0.38 ^f | 2.10–3.23 |

Abbreviation: LPG, liquefied petroleum gas.

^aLower heating value—https://www.engineeringtoolbox.com/fuels-higher-calorific-values-d_169.html (accessed June 20, 2024).

^bEnzo Coccia (Personal communication).

^c<https://giardinodel.it/scopri-prezzo-legna-quintale-confronto-regioni/> (accessed June 20, 2024).

^d<https://www.sostariffe.it/energia-elettrica-gas/faq/quanto-costa-un-metro-cubo-smc-di-gas-metano> + spese di trasporto, gestione contatore + oneri di sistema + imposte (accessed June 20, 2024).

^e<https://www.prontobolletta.it/prezzo-gas/gpl-riscaldamento/> (accessed June 20, 2024).

^f<https://www.sostariffe.it/energia-elettrica-gas/faq/costo-kwh-kilowattora-quanto-costa-l-energia-elettrica> + spese di trasporto, gestione contatore + oneri di sistema + imposte (accessed June 20, 2024).

TABLE 4 Recommendations and considerations for pizza oven selection.

| Oven selection considerations | Temperature profile | Materials and thermal inertia | Access for rotation | Smoke and water filter systems | Efficiency improvements | Operating costs |
|-------------------------------|---|---|---|---|---|--|
| Wood-fired | Optimal | Assured by installing appropriate refractory and insulating materials | Provided, unless equipped with a rotating cooking floor | Mandatory in case of local antipollution laws | Assured by proper insulation of the oven dome and floor, and use of patented Air Trap System ^(R) | Most economical option (€0.92/h), if firewood costs €0.15/kg |
| Gas LPG | To be improved especially to avoid quick decrease in the oven floor temperature | Idem | Idem | Generally unneeded | Idem | €2.70–€4.10/h €5.30–€6.19/h |
| Electric | Optimal provided that the oven dome and floor are equipped with appropriate thermal resistances | Idem | Generally, the oven door is closed to limit heat losses | Unneeded | It can be assured by proper insulation of the oven dome and floor | €2.10–€3.23/h, depending on electricity prices and supply contract |

Abbreviation: LPG, liquefied petroleum gas.

AVPN to allow the use of gas or electric ovens if installing a wood-fired oven is impossible due to local authorization issues. However, these alternative ovens must be certified by the AVPN to ensure they operate in accordance with traditional wood-fired ovens.

Among the types of pizza ovens currently used worldwide, it is worth noting that:

1. *Wood-fired ovens* are widely used for cooking True Neapolitan Pizza, as they offer intense and even heat, essential for rapid cooking and optimal results. The combustion of wood also imparts the characteristic smoky flavor appreciated by consumers. These ovens are preferred by traditionalists adhering to True Neapolitan Pizza guidelines.

2. *Gas pizza ovens* are a convenient alternative to wood-fired ovens, as they can reach high temperatures relatively quickly. Their main challenge is maintaining a consistent and even temperature to guarantee accurate pizza cooking.
3. *Electric pizza ovens* offer greater control over temperature and heat distribution compared to wood-fired and gas ovens. They can be designed to faithfully replicate the baking conditions of wood-fired ovens, but it is crucial to ensure they have specific features like powerful heating elements and good air circulation to achieve optimal results. Their ease of use and potential operational cost savings from the installation of photovoltaic panels could promote their adoption as a viable tool for spreading Neapolitan pizza in urban areas or countries where environmental concerns about fine particle emissions make it difficult to obtain permits for wood-fired ovens.

When selecting the appropriate pizza oven, the following aspects should be considered:

1. *Temperature profile*: The pizza ovens should ensure a temperature profile that guarantees quick cooking; otherwise, the pizza will become dry and overcooked.
2. *Materials and thermal inertia*: The pizza oven should be made with materials with adequate thermal inertia to maintain stable cooking conditions and allow for quick temperature recovery for subsequent bakes; otherwise, the pizza will become rubbery.
3. *Access for rotation*: The pizza oven should provide access to the pizza to allow for rotation during baking to prevent excessive burning in the bottom area.
4. *Smoke and water filter systems*: The oven hood should be equipped with smoke exhaust and water filter systems to minimize fine particle emissions indoors and outdoors.
5. *Efficiency improvements*: Particular attention should be given to minimizing heat loss during oven operation and improving its thermal efficiency to decrease the amount of energy supplied during baking.

Recommendations and considerations for pizza oven selection are summarized in Table 4.

Although numerous internet sources compare the quality of pizzas baked in gas, electric, and wood-fired ovens, a systematic comparative sensory assessment is still lacking. Generally, pizzas baked in wood-fired ovens are celebrated for their distinctive texture, featuring a crispy crust with a slightly smoky flavor and a chewy interior. As discussed in the manuscript, gas and electric ovens can also produce excellent pizzas, though they often result in some textural differences. Gas ovens typically

produce a consistent but slightly less crispy crust, whereas electric ovens may struggle to reach the high temperatures required for achieving the traditional wood-fired texture.

7 | CONCLUSION

Understanding the phenomenology of pizza baking is crucial for reducing variability and maximizing the quality attributes of Neapolitan pizza. Selecting the most appropriate oven involves considering temperature control, materials, ease of pizza rotation, emission control, energy efficiency, and operating costs. Wood-fired ovens are the most economical if firewood remains affordable, but natural gas and electric ovens offer competitive alternatives depending on local conditions.

In conclusion, although alternative ovens can meet the technical requirements for cooking true Neapolitan pizza, it is essential to emphasize the importance of the Pizzaiolo's experience and skill in preparing this delicacy, regardless of the type of oven used.

AUTHOR CONTRIBUTIONS

Aniello Falciano: Conceptualization; investigation; writing—review and editing. **Paolo Masi**: Conceptualization; investigation; funding acquisition; writing—review and editing; project administration. **Mauro Moresi**: Conceptualization; investigation; writing—original draft; writing—review and editing; methodology.

ACKNOWLEDGMENTS

Open access publishing facilitated by Università degli Studi della Tuscia, as part of the Wiley - CRUI-CARE agreement.

CONFLICT OF INTEREST STATEMENT

The authors declare no conflicts of interest.

DATA AVAILABILITY STATEMENT

The datasets generated during and/or analyzed during the current study are available from the corresponding author on reasonable request.

ORCID

Aniello Falciano  <https://orcid.org/0000-0001-5924-3152>

Paolo Masi  <https://orcid.org/0000-0003-2338-0651>

Mauro Moresi  <https://orcid.org/0000-0002-4706-0129>

REFERENCES

- Aldighieri, R., Zanini, K., & Degli Angeli, A. D. (2010). The industrial technology of Neapolitan pizza. *Industrie Alimentari*, 49, 16–21.
- Apurva. (2016). *Tandoors, burning of solid waste adding to dirty Delhi air: IIT study*. The Indian Express. <https://indianexpress.com/>

- article/india/india-news-india/tandoors-burning-of-solid-waste-adding-to-dirty-delhi-air-iiit-study/
- AVPN (Associazione Verace Pizza Napoletana). (2020). *Lo Scugnizzo Napoletano diventa "VERACE". L'AVPN approva il 1° Forno Elettrico per la Pizza Napoletana*. https://www.pizzanapoletana.org/it/71-lo-scugnizzonapoletano-diventa-verace_1_avpn_approva_il_1_forno_elettrico_per_la_pizza_napoletana
- AVPN (Associazione Verace Pizza Napoletana). (2024). *Disciplinare internazionale per l'ottenimento del marchio collettivo Verace Pizza Napoletana (vera pizza napoletana)*. <https://www.pizzanapoletana.org/public/pdf/Disciplinare-2024-ITA.pdf>
- Morrone, B., & Ciarmiello, M. (2018). Innovative electric ovens for pizza baking: Numerical thermal investigation. *High Temperature Material Processes*, 22(2–3), 115–140. <https://doi.org/10.1615/HighTempMatProc.2018024507>
- Caporaso, N., Panariello, V., & Sacchi, R. (2015). The “True” Neapolitan Pizza: Assessing the influence of extra virgin olive oil on pizza volatile compounds and lipid oxidation. *Journal of Culinary Science and Technology*, 13(1), 29–48. <https://doi.org/10.1080/15428052.2014.952476>
- Ciarmiello, M., & Morrone, B. (2016a). Numerical thermal analysis of an electric oven for Neapolitan pizzas. *International Journal of Heat and Technology*, 34, Special Issue (2), S351–S358. <https://doi.org/10.18280/ijht.34S223>
- Ciarmiello, M., & Morrone, B. (2016b). Why not using electric ovens for Neapolitan pizzas? A thermal analysis of a high temperature electric pizza oven. *Energy Procedia*, 101, 1010–1017. <https://doi.org/10.1016/j.egypro.2016.11.128>
- Ciarmiello, M., Morrone, B., & Trasacco, F. (2017). Thermal investigation of baking Neapolitan pizzas in innovative electric oven. *International Symposium on Advances in Computational Heat Transfer*, pp. 899–910. <https://doi.org/10.1615/ichmt.2017.930>
- Covino, C., Sorrentino, A., Di Pierro, P., & Masi, P. (2023). Study of physico-chemical properties of dough and wood oven-baked pizza base: The effect of leavening time. *Foods*, 12(7), 1407. <https://doi.org/10.3390/foods12071407>
- Deacon, H. (2018). Safeguarding the art of pizza making: Parallel use of the traditional specialties guaranteed scheme and the UNESCO intangible heritage convention. *International Journal of Cultural Property*, 25(4), 515–542. <https://doi.org/10.1017/S0940739118000279>
- De Falco, S. (2018). Vesuvius, pizza, coffee and... Innovation: Is a new paradigm possible for the creative “Vesuvius Valley”, Naples, Italy? *City, Culture and Society*, 14, 1–13. <https://doi.org/10.1016/j.ccs.2018.03.002>
- Della Corte, T., Gentile, S., Guarino, G., Satta, E., Romano, C., Alfarone, C., & Strollo, F. (2020). How to make a mix of low glycemic index flours for a good Neapolitan pizza for patients with diabetes. *Diabetes and Metabolic Syndrome: Clinical Research and Reviews*, 14(4), 459–462. <https://doi.org/10.1016/j.dsx.2020.04.030>
- EC. (2010). Commission Regulation (EU) No. 97/2010, Entering a Name in the Register of Traditional SPECIALITIES guaranteed [Pizza Napoletana (TSG)]. *Official Journal of the European Union*, 34, 5. <https://eur-lex.europa.eu/legal-content/EN/TXT/HTML/?uri=OJ:L:2010:034:FULL>
- EFSA (European Food Safety Authority). (2015). *Outcome of the public consultation on the draft scientific opinion of the EFSA panel on contaminants in the food chain (CONTAM) on acrylamide in food*. EFSA Support. Publ. 2015, EN-817. <https://efsa.onlinelibrary.wiley.com/doi/pdf/10.2903/sp.efsa.2015.EN-817>
- Falciano, A., Cimini, A., Masi, P., & Moresi, M. (2022c). Carbon footprint of a typical Neapolitan pizzeria. *Sustainability*, 14(5), 3125. <https://doi.org/10.3390/su14053125>
- Falciano, A., Masi, P., & Moresi, M. (2022a). Performance characterization of a traditional wood-fired pizza oven. *Journal of Food Science*, 87, 4107–4118. <https://doi.org/10.1111/1750-3841.16268>
- Falciano, A., Masi, P., & Moresi, M. (2023a). Semiempirical modeling of a traditional wood-fired pizza oven in quasi-steady-state operating conditions. *Journal of Food Science*, 88(5), 2036–2052. <https://doi.org/10.1111/1750-3841.16532>
- Falciano, A., Moresi, M., & Masi, P. (2023b). Phenomenology of Neapolitan pizza baking in a traditional wood-fired oven. *Foods*, 12(4), 890. <https://doi.org/10.3390/foods12040890>
- Falciano, A., DPierro, P. D., Sorrentino, A., Cavella, S., Masi, P., & Romano, A. (2023c). Study of medium-high shelf life ready-to-use dough rolls for making “pizza Napoletana”. *Italian Journal of Food Science*, 35(4), 130–135. <https://doi.org/10.15586/ijfs.v35i4.2328>
- Falciano, A., Puleo, S., Colonna, F., Moresi, M., Di Monaco, R., & Masi, P. (2023d). Novel high-quality takeaway Neapolitan pizza from unused dough balls: Hedonic and textural properties, and carbon footprinting assessment. *International Journal of Food Science and Technology*, 58(8), 4332–4343. <https://doi.org/10.1111/ijfs.16534>
- Falciano, A., Sorrentino, A., Masi, P., & Di Pierro, P. (2022). Development of functional pizza base enriched with jujube (*Ziziphus jujuba*) powder. *Foods*, 11(10), 1458. <https://doi.org/10.3390/foods11101458>
- Ferulano, E. (2021). Chapter 35: From a Neapolitan perspective, reaching out beyond prevailing cultural models. In M. Lancione & C. McFarlane (Eds.), *Global urbanism: Knowledge, power and the city* (pp. 298–305). Routledge. <https://doi.org/10.4324/9780429259593-40>
- Fucito, A. (2020). *Forno elettrico e pizza napoletana: parola ai Pizzaioli, Tecnici, Associazioni*. <https://garage.pizza/rubriche-sulla-pizza/forno-elettrico-e-pizza-napoletana-parola-ai-pizzaioli-tecnici-associazioni/>
- Furlanis, E. (2017). *Meglio il forno a legna o quello elettrico?* <https://www.accademia-pizzaioli.it/meglio-il-forno-a-legna-o-quello-elettrico/>
- Idelson, P. I., Russo, O., Iacone, R., D’Elia, L., Giacco, R., Volpe, M. G., & Strazzullo, P. (2020). A lower sodium Neapolitan pizza prepared with seawater in place of salt: Nutritional properties, sensory characteristics, and metabolic effects. *Nutrients*, 12(11), 3533, 1–15. <https://doi.org/10.3390/nu12113533>
- Jones, J. M., Mason, P. E., & Williams, A. (2019). A compilation of data on the radiant emissivity of some materials at high temperatures. *Journal of the Energy Institute*, 92(3), 523–534. <https://doi.org/10.1016/j.joei.2018.04.006>
- Lima, F. D. M., Pérez-Martínez, P. J., Andrade, M. D. F., Kumar, P., & de Miranda, R. M. (2020). Characterization of particles emitted by pizzerias burning wood and briquettes: A case study at Sao Paulo, Brazil. *Environmental Science and Pollution Research*, 27, 35875–35888. <https://doi.org/10.1007/s11356-019-07508-6>
- Masi, P., Romano, A., & Coccia, E. (2015). *The Neapolitan pizza. A scientific guide about the artisanal process*. DoppiaVoce.

- Morris, C. F., & Ibba, M. I. (2018). Regarding Neapolitan pizza “Pizza Napoletana”. *Cereal Chemistry*, 95(3), 365–366. <https://doi.org/10.1002/cche.10052>
- NCI (National Cancer Institute). (2017). *Acrylamide and cancer risk*. <https://www.cancer.gov/about-cancer/causes-prevention/risk/diet/acrylamide-fact-sheet>
- New York City Administrative Code. (2016). *Environmental protection and utilities*. <https://www.nyc.gov/assets/dep/downloads/pdf/air/air-pollution-control-code.pdf>
- Nierenberg, A. (2024). *Goodbye, gas. The future of New York City's pizza is electric*. <https://www.nytimes.com/2024/04/30/dining/new-york-pizza-electric-ovens.html>
- Pagani, M. A., Lucisano, M., & Mariotti, M. (2014). Italian bakery products. In W. Zhou, Y. H. Hui, I. De Leyn, M. A. Pagani, C. M. Rosell, J. D. Selman, & N. Therdthai (Eds.), *Bakery products science and technology* (2nd ed., pp. 685–721). John Wiley & Sons, Ltd. <https://doi.org/10.1002/9781118792001.ch40>
- Piscopo, A., Mincione, A., Summo, C., Silletti, R., Giacondino, C., Rocco, I., & Pasqualone, A. (2024). Influence of the mozzarella type on chemical and sensory properties of “Pizza Margherita”. *Foods*, 13(2), 209. <https://doi.org/10.3390/foods13020209>
- Piscopo, A., Zappia, A., Mincione, A., Silletti, R., Summo, C., & Pasqualone, A. (2023). Effect of oil type used in Neapolitan pizza TSG topping on its physical, chemical, and sensory properties. *Foods*, 12(1), 41. <https://doi.org/10.3390/foods12010041>
- Research & Markets. (2024). *Pizza market report by type (non-vegetarian pizza, vegetarian pizza), crust type (thick crust, thin crust, stuffed crust), distribution channel (quick service restaurants (QSR), full-service restaurants (FSR), and others), and region 2024–2032*. <https://www.imarcgroup.com/pizza-market>
- Singh, B., & Highway, D. (2016). *What is your restaurant's carbon footprint?* <https://www.pizzamarketplace.com/articles/what-is-your-restaurants-carbon-footprint/>
- Stazio, M. (2021). Verace Glocal Pizza. Localized globalism and globalized localism in the Neapolitan artisan pizza. *Food, Culture and Society*, 24(3), 406–430. <https://doi.org/10.1080/15528014.2021.1884400>
- The Engineering ToolBox. (2003). *Solids, liquids and gases—Thermal conductivities*. https://www.engineeringtoolbox.com/thermal-conductivity-d_429.html
- UNESCO (United Nations Education, Scientific and Cultural Organization). (2017). *Decision of the Intergovernmental Committee: 12.COM 11.B.17*. <https://ich.unesco.org/en/decisions/12.COM/11.B.17>
- WHO (World Health Organization). (2022). *Ambient (outdoor) air pollution*. [https://www.who.int/news-room/fact-sheets/detail/ambient-\(outdoor\)-air-quality-and-health](https://www.who.int/news-room/fact-sheets/detail/ambient-(outdoor)-air-quality-and-health)

How to cite this article: Falciano, A., Masi, P., & Moresi, M. (2024). Unlocking the secrets of Neapolitan pizza: A concise review of wood-fired, electric, and gas pizza ovens. *Journal of Food Science*, 89, 6966–6984. <https://doi.org/10.1111/1750-3841.17417>